

FORGED CHECK VALVE

PRODUCT RANGE

Size	15 mm - 50 mm
MOC	FCS - ASTM A105 SS304 - ASTM A182 Gr. F304 SS316 - ASTM A182 Gr. F316
End Connection	Screwed BSP / NPT Socket Weld / Butt Weld Flange End 150# - 600#

APPLICABLE STANDARDS

Design Std.	ISO 15761
Screwed End	ASME B1.20.1
Socket Weld	ASME B 16.11
Butt Weld End	ASME B16.25
Flange End	ASME B16.5, RF
Face to Face	Mfg Std / ASME B16.10 (Flange)
Testing Standard	API 598
Pressure/Temp	ASME B16.34

DESIGN FEATURES

- Lift Type Check Valve
- Bolted Bonnet
- Pressure Seal Bonnet
- Pressure Rating : 800# / 1500# / 2500#
- SS304 L / SS316 L MOC



Screwed / SW End



Flange End

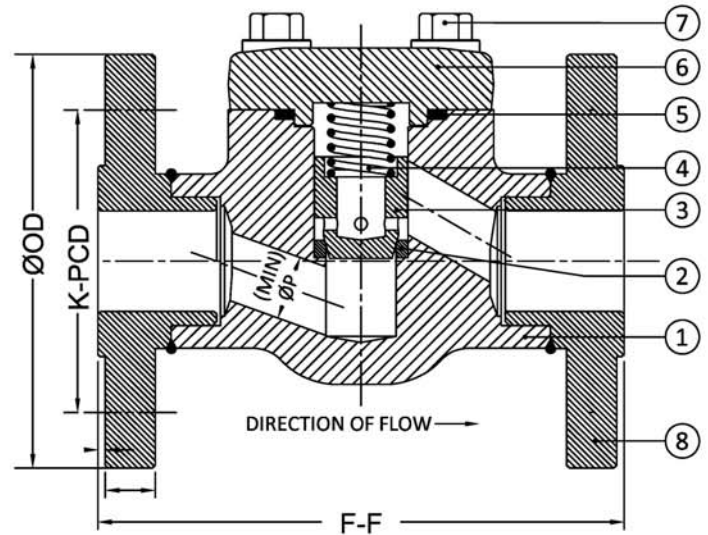
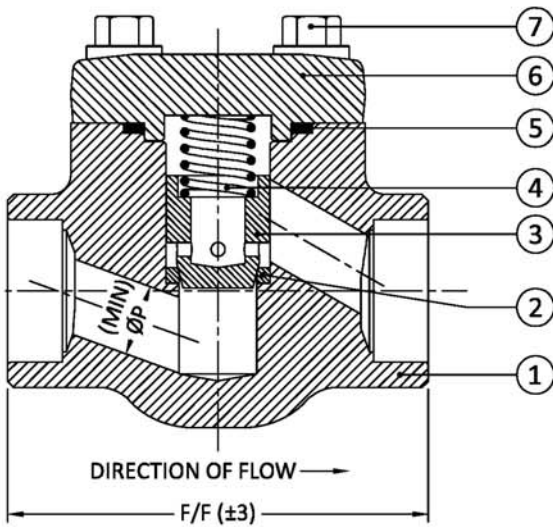

Forged Check Valve - 800#				
Size	F-F	P	H	
15 mm	87	9.5	53	
20 mm	92	12.7	56	
25 mm	106	17.5	66	
40 mm	127	28.6	86	
50 mm	142	36.5	104	

P. NO.	PART NAME	MATERIAL
1	Body	A105 / F304 / F316
2	Seat Ring	SS410 / SS304 / SS316 / Integral
3	Disc	SS410 / SS304 / SS316
4	Spring	SS304
5	Gasket	SPW SS304 + GRAPHOIL
6	Bonnet	A105 / F304 / F316
7	Hex Bolt	ASTM A193 Gr. B7 / B8 / B8M

Forged Lift Check Valve-Flange 150#				
Size	F-F	OD	PCD	ØH
15 mm	108	90	60.3	4-16
20 mm	117	100	69.9	4-16
25 mm	127	110	79.4	4-16
40 mm	165	125	98.4	4-16
50 mm	203	150	120.7	4-19