



INSTANT HOT WATER GENERATOR FOR PROCESS HEATING

UNIKLINGER, in keeping with the Innovative Methods to help Process Industry achieve higher levels of operational efficiency have

UKL PACKAGE HOT WATER SYSTEM – In Modular Designs.

(Custom Built Packages for flow-rates up to 10KLPH are available on request)

With the space availability at high premium, one needs a Quick, Efficient and Reliable source of Hot Water for process heating applications. And this is the hallmark of UKL HWG System as with all other UKL products and services.

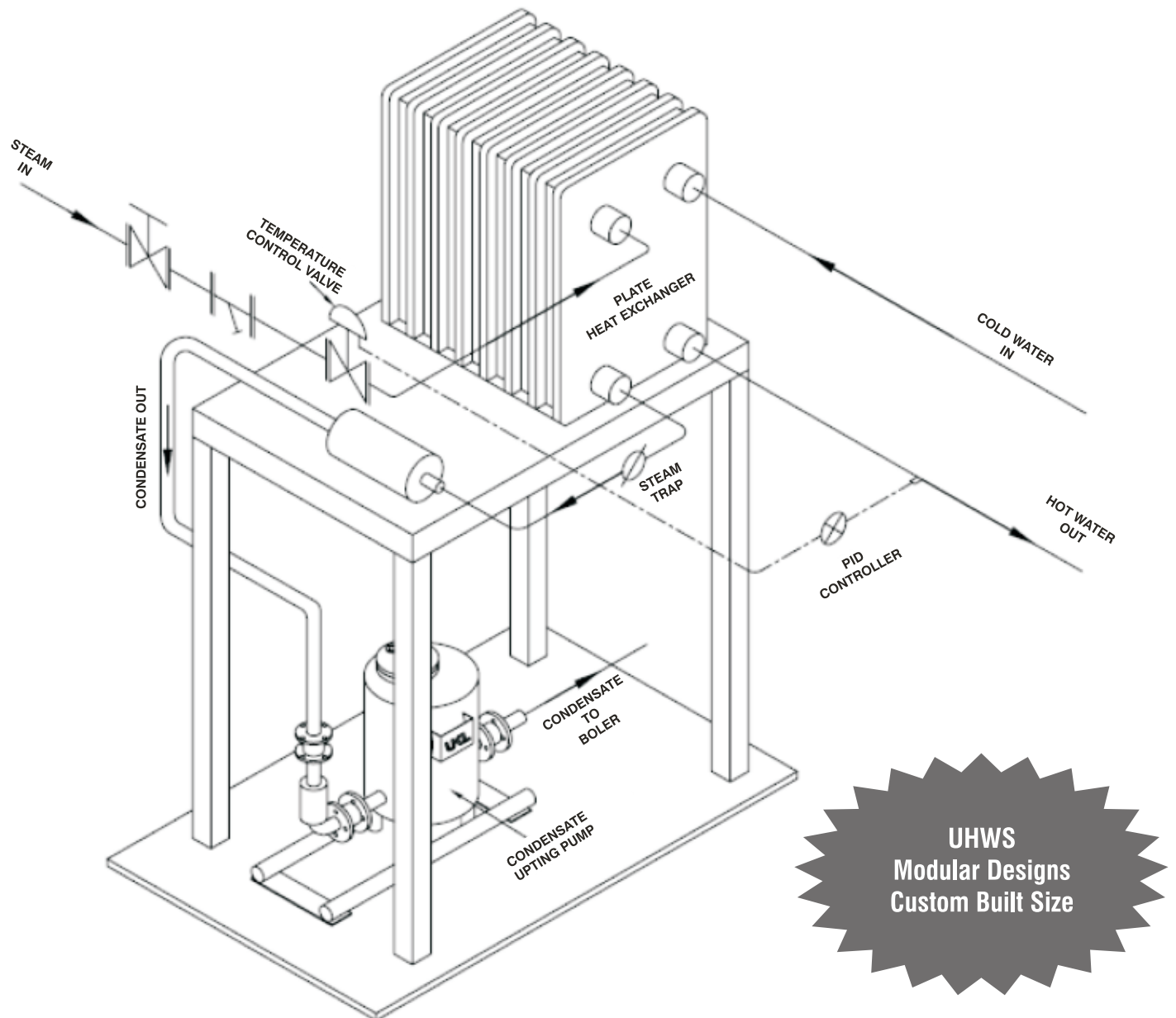



Few of the many reasons to go for UKL HWG System

- Instant supply of hot water with efficient flow modulation.
- Efficiency optimization guaranteed due to custom-built design.
- Outlet temperature adjustments to suit variety of applications.
- Compact skid mounted unit with sleek finish.
- 100% Condensate removal and recycling.
- Insulation of all hot surfaces with a novel surface coating method.

Capacities and dimensions will depend on the output requirements

Uniklinger has lot more to offer than the Revolutionary range of Piston Valves and Klinger Sealing Material.

Complete Range of Steam Traps and Accessories
Pressure & Temperature Control Systems
Flash Steam and Condensate Recycling Packages
Compact Steam/Condensate Manifolds and TVS
Strainers & Moisture Separators

Leak Monitoring Systems

Steam and Thermal Audits
Consultancy Service for Steam and Condensate
Training & Manpower Evaluation on Steam Engineering



Cast / Forged Steel Valves, Piston Valves, Strainers - 'Y' Type



Steam Traps - Thermodynamic, Thermostatic, Ball Float Traps, IBT, / Pressure Reducing Station

Manual & Actuated Ball & Butterfly Valves / Bellow Sealed Valve / Level Gauges - Reflex, Transparent. Bicolor, Condensate Recovery Products

In view of technical progress designs and dimensions are subject to change without notice.



UNI KLINGER LIMITED

A joint venture of the Neterwala group of companies and KLINGER AG, Switzerland.

Sales Office : Sc1, 5th Fl., Kohinoor Est. Mumbai-Pune Highway, Khadki, Pune-411003
Tel. : 91- 20-41023000 Fax: (020) 41023001
e-mail : salescsso@uniklinger.com / salespune@uniklinger.com
Website : www.uniklinger.com



- AN ISO 9001 : 2008
COMPANY.

Factories :

C - 37, M.I.D.C., Ahmednagar - 414111. Maharashtra. Tel.: 0241 - 2777223 / 2777512 Fax: 0241 - 2777294. E-mail: fcdworks@uniklinger.com

Branch Offices :

Baroda :
102, Offitel Towers II,
1st Floor,
R.C. Dutt Road,
Baroda- 390 005.
Tel.: 91-265-2312343/2340660
Fax : 91-265-2341419
e-mail :
salesbar@uniklinger.com

Chennai :
East Coast Centre,
5th Floor, 553, Mount Rd.,
Teyanampet,
Chennai- 600 018.
Tel.: 91-44-24345707
Fax :91-44 -24343960.
e-mail :
saleschen@uniklinger.com

Kolkata :
9, 'CHITRAKOOT',
8th Floor, 230 A,
AJC Bose Road,
Kolkata- 700 020.
Tel.: 91-33-22872510
Fax: 91-33-22876494
e-mail :
salescal@uniklinger.com

Mumbai:
A-204, Nagesh Co-op. Hsg. Soc.,
LBS Marg, Navapada,
Thane-400 602.
Tel. :91-22-25421140
91-22-25440461
Fax:91-22-25440463
e-mail :
salesmum@uniklinger.com

New Delhi:
321, Ansal Chamber-II,
6, Bhikaji Cama Place,
New Delhi-110 066.
Tel.: 91-11-41658767
91-11-26193847
Fax: 91-11-41658768
e-mail :
salesdel@uniklinger.com